

**TECHNICAL SPECIFICATION**  
**MODEL: ULTIMATE II JUDO GI**

Customer: \_\_\_\_\_

CHART REF: \_\_\_\_\_

ARTICLE No. \_\_\_\_\_

**340**

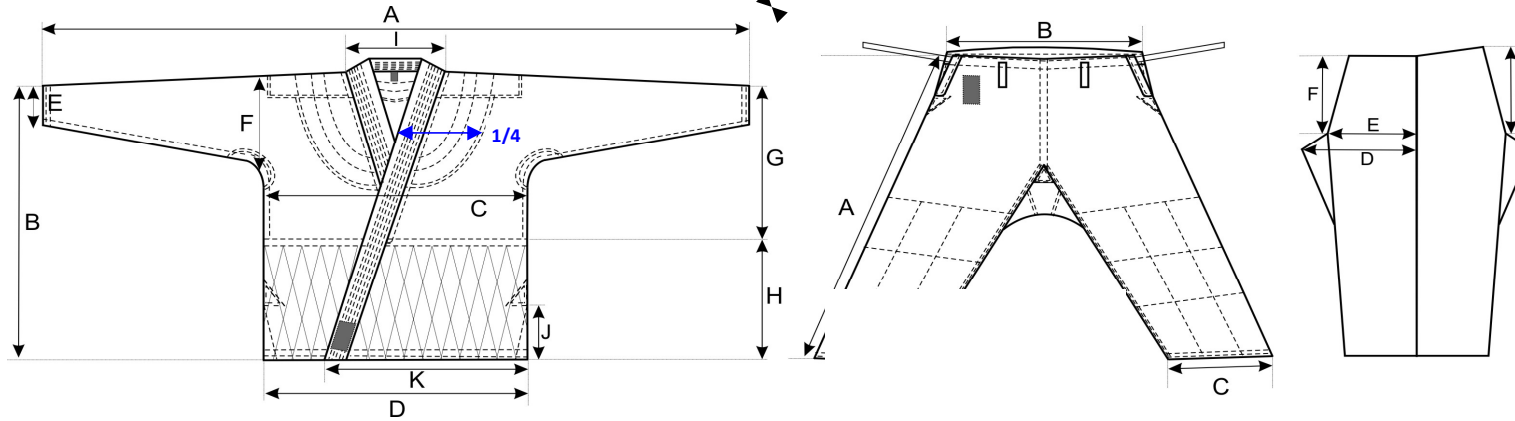

UNIT = CM

Tolerance		JACKET										PANT							BELT			
		± 1.5%	± 2%	± 2%	± 2%	± 5%	± 4%	± 1.5%	± 1.5%	± 5%	± 3%	± 3%	± 1.5%	± 3%	± 4%	± 3%	± 4%	± 5%	± 5%			M
NO.	CM	A	B	C	D	E	F	G	H	I	J	K	A	B	C	D	E	F	G			
	130	120	64	41	43	15	20	33	31	20	17		78	38/44	19	34	24	16	19			
	140	130	68	45	47	16	21	35	33	21	18		84	40/46	21	36	26	17	20			
	145	134	70	47	49	16	24	36	34	21	19		86	42/48	22	37	27	17	20			
	150	138	72	49	51	17	25	37	35	22	19		88	44/50	23	38	28	18	21			
	155	142	74	52	53	17	26	38	36	22	20		90	46/52	23	39	29	18	21			
	160	146	76	54	56	18	27	39	37	23	20		90	48/54	24	40	30	19	22			
	165	150	78	57	59	19	27	40	38	23	21		94	50/56	25	41	31	19	22			
	170	156	82	59	61	20	28	42	40	24	22		97	52/58	26	42	32	20	23			
	175	160	86	62	64	21	29	44	42	24	23		99	54/60	26	45	34	21	24			
	180	166	88	64	66	22	30	45	43	25	24		102	56/62	27	46	35	22	25			
	185	172	90	66	68	22	30	46	44	25	24		104	57/63	27	47	35	22	25			
	190	178	92	68	70	23	31	47	45	26	25		106	58/64	28	48	36	23	26			
	195	183	94	71	73	23	31	48	46	26	25		108	60/66	28	49	37	23	26			
	200	188	97	73	75	24	32	50	47	27	26		110	62/68	29	49	37	24	27			
	205	193	100	76	78	24	32	51	49	27	27		112	63/67	29	50	38	24	27			
	210	196	104	78	80	25	33	53	51	28	28		114	64/70	30	50	38	25	28			